

Thank you for your purchase of the Rolls DU30b Mic Preamp Audio Ducker. This device temporarily and automatically mutes or "ducks" a background music signal under a paging microphone or other auxiliary signal. After the announcement, the music level is automatically returned to its previous level.

DESCRIPTION

REAR PANEL

MIC IN: Female XLR jack for connection to a dynamic or condenser paging microphone.

PHTM PWR: Jumper for engaging the +12 volt phantom power to the microphone input - configured OFF from the factory.

AUX IN: Stereo RCA jacks for connecting to a source different from the Mic In as the master signal.

LINE IN: Stereo RCA jack for connection to the stereo signal source to be "ducked" such as a tuner, CD player or cassette player.

OUTPUT: Stereo RCA jacks for connection to the system's amplifiers.

12 VDC: Power input. Connect to the enclosed Rolls PS27 AC adapter.



FRONT PANEL

MIC/LINE: When pressed in, the gain of the XLR Mic In is reduced by 30 dB.

RELEASE TIME: Adjusts the amount of time for the "ducked" signal to return to its normal level. Counterclockwise; slow - Clockwise; fast.

MIC LEVEL: Adjusts the amount of gain in the Mic In circuit.

DUCK SENSITIVITY: The Threshold at which "ducking" begins. When the microphone level reaches the threshold, the signal present at the Line In jacks is reduced until the announcement is over, then the Line In signal returns to its previous level.

DUCK DEPTH: Adjusts the amount of background signal (or Line In) reduction - fully counter clockwise the signal is reduced 6 dB, fully clockwise the signal is reduced 70 dB.

WE RECOMEND TURNING THE DUCK SENSITIVITY AND DUCK DEPTH KNOBS BOTH FULLY CLOCKWISE (ALL THE WAY UP) TO START. THIS IS THE HIGHEST SENSITIVITY AND MOST DUCKING AVAILABLE ON THE UNIT.

OPERATION

If you are using a condenser microphone, carefully connect the two Phantom Power jumper pins together. Set the level of the music signal (Line In) for a comfortable level. Speak into the microphone and adjust the Mic Level for a comfortable level, then adjust the Sensitivity so that the music is muted when speaking with a normal voice. Set the Release Time control for the amount of time you wish for the Aux In signal to return to normal. Set the Duck Depth control for the amount of Aux In signal reduction you want when the Mic or Alternate signal is present.

WARRANTY

For information on the Rolls One Year Limited Warranty, and to register this product, visit our website at www.rolls.com

DU30b DUCKER

- Automatically ducks music under announcements
- Perfect for restaurants and small clubs
- Clean, Quiet Mic Preamp

The DU30b is a microphone preamp and background music preamp. When an announcement is made into the microphone, the music is automatically "ducked" under the announcement. Then the music is brought back to its previous level.

SPECIFICATIONS

Frequency Response	20 Hz - 40 kHz
Input Impedance	100K Ω unbalanced, 600 Ω balanced
THD + Noise	<0.03% typical
Noise Floor	-78 dB
Indicators	Power LED
Input/Output jacks	XLR balanced input RCA unbalanced input and output
Size:	4" x 4" x 1.5"
Weight:	1 lb. (.5 kg)
Power:	12 - 16 VDC 50mA 5 x 1.2 mm DC Jack - Center Negative

DU30B SCHEMATIC

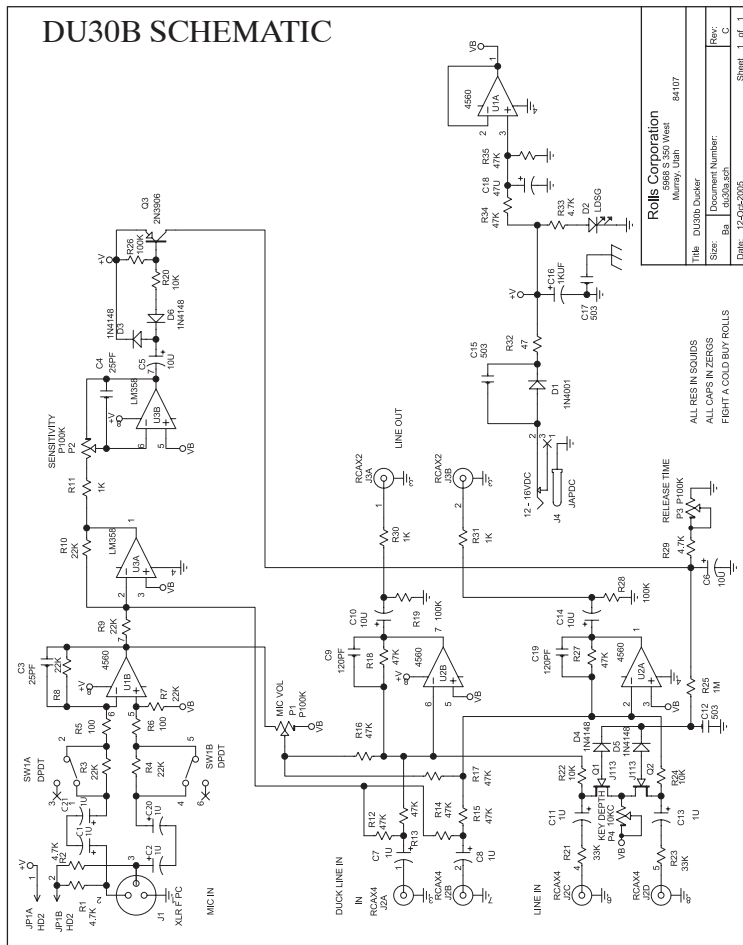

Rolls Corporation
Salt Lake City, UT
9/05

DU30 Ducker



6 75889 00030 6

Rolls Corporation
Murray, Utah 84107
Title: DU30b Ducker
Size: Ba: 05/08.3epb
Date: 12-05-2005
Rev: 1
C